

SUPER W1 Heavy-duty Clamp



W1

Mikalor was the first company to design and produce a heavy-duty hose clamp, and since then the Super clamp has gone from strength to strength.

The high strength 8.8 grade steel nut and T-bolt mean that Super can be tightened up hard using many different kinds of tools, while the beveled edges protect the hose from harm.

The Super clamp is in its element in agricultural applications, waste water extraction, mining, quarrying or in other sectors where a rugged yet competitively priced heavy-duty clamp is required.

*** The maximum application pressure can vary depending on the type of hose used and the geometry of the coupling.**

Ø D Application mm	Part Number	Ø D ±0.2	A +0.3 -0	S ±0.03	B ±0.5	F ±0.03	Maximum values		Box Quantity	Outer Box Quantity
							Pressure (Bar)	Torque (Nm)		
17-19	03018263	19	18	0,6	19,8	1,5	48	4,5	50	400
20-22	03018271	22	18	0,6	19,8	1,5	48	4,5	50	400
23-25	03018280	25	18	0,6	19,8	1,5	45	4,5	50	400
26-28	03018298	28	18	0,6	19,8	1,5	45	4,5	50	400
29-31	03018300	31	20	0,8	22,0	1,7	42	8,0	50	50
32-35	03018319	35	20	0,8	22,0	1,7	42	8,0	50	50
36-39	03018327	39	20	0,8	22,0	1,7	40	8,0	50	50
40-43	03018335	43	20	0,8	22,0	1,7	40	8,0	50	50
44-47	03018010	47	22	1,2	24,5	2,0	44	16,0	50	50
48-51	03018028	51	22	1,2	24,5	2,0	44	16,0	50	50
52-55	03018036	55	22	1,2	24,5	2,0	40	16,0	25	25
56-59	03018044	59	22	1,2	24,5	2,0	40	16,0	25	25
60-63	03018052	63	22	1,2	24,5	2,0	36	16,0	25	25
64-67	03018060	67	22	1,2	24,5	2,0	36	16,0	25	25
68-73	03018079	73	25	1,5	26,5	2,5	28	25,0	25	25
74-79	03018087	79	25	1,5	26,5	2,5	28	25,0	25	25
80-85	03018095	85	25	1,5	26,5	2,5	28	25,0	25	25
86-91	03018108	91	25	1,5	26,5	2,5	20	25,0	25	25
92-97	03018116	97	25	1,5	26,5	2,5	20	25,0	25	25
98-103	03018124	103	25	1,5	26,5	2,5	20	25,0	25	25

≈

Ø D Application mm	Part Number	Ø D ±0.2	A +0.3 -0	S ±0.03	B ±0.5	F ±0.03	Maximum values		Box Quantity	Outer Box Quantity
							Pressure (Bar)	Torque (Nm)		
104-112	03018132	112	25	1,5	26,5	2,5	12	25,0	25	25
113-121	03018140	121	25	1,5	26,5	2,5	12	25,0	25	25
122-130	03018159	130	25	1,5	26,5	2,5	12	25,0	25	25
131-139	03018167	139	26	1,7	29,0	2,5	9	25,0	10	10
140-148	03018175	148	26	1,7	29,0	2,5	9	25,0	10	10
149-161	03018183	161	26	1,7	29,0	2,5	9	25,0	10	10
162-174	03018191	174	26	1,7	29,0	2,5	6	25,0	10	10
175-187	03018204	187	26	1,7	29,0	2,5	6	25,0	10	10
188-200	03018212	200	26	1,7	29,0	2,5	6	25,0	10	10
201-213	03018220	213	26	1,7	29,0	2,5	3	25,0	10	10
214-226	03018239	226	26	1,7	29,0	2,5	3	25,0	10	10
227-239	03018247	239	26	1,7	29,0	2,5	3	25,0	10	10
240-252	03018255	252	26	1,7	29,0	2,5	3	25,0	10	10

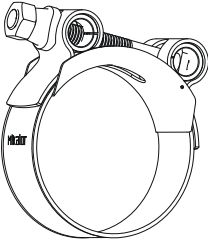
TECHNICAL INFORMATION	
	MATERIAL Soft F111 Steel W1 band Steel screw Qst 36-3 (DIN 1.0213) Steel nut (DIN 1.0333)
	FINISH Galvanized
	CORROSION RESISTANCE 72 hours salt spray (ASTM B-117)
	MAX. TIGHTENING SPEED (RPM) 540 ± 5

